

CLEANING PROTOCOL

SOCOREX 525/530 CALIBREX™ DISPENSER (25, 50, 100ml)

TO MAINTAIN CALIBREX DISPENSERS IN OPTIMUM WORKING CONDITION IT IS IMPORTANT THAT THESE SIMPLE CLEANING PROCEDURES ARE ROUTINELY FOLLOWED.

CLEANING ON A DAILY BASIS

- Remove dispenser from dosing bottle.
- Thoroughly rinse the unit in hot water.
- Flush the inside of the unit with hot water by drawing up via the plunger and feed tube.

CLEANING ON A WEEKLY BASIS

AT LEAST ONCE A WEEK WE RECOMMEND DISASSEMBLING THE UNIT FOR COMPLETE CLEANING OF ALL INTERNAL COMPONENTS

- Purge dispenser before removing from bottle
- Remove dispenser from dosing bottle
- Repeat daily cleaning procedure
- Unscrew plunger head (4)
- Unscrew connecting body nut to access glass barrel (5) valve body (13) and plate (11)
- Be careful not to lose the valve ball (12)
- Unscrew delivery jet nut (15) and separate from dispenser
- Soak all units in mild laboratory detergent, ensuring that all residue is removed
- Dry components
- Reassemble unit

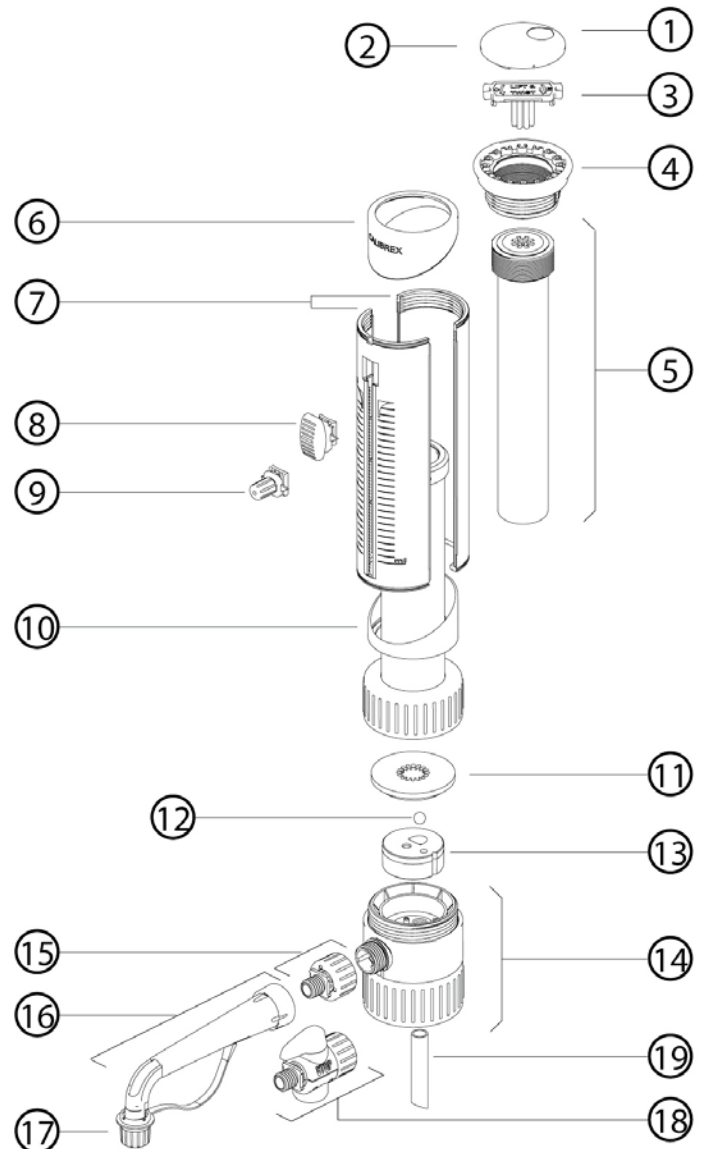

Dispensers must be thoroughly cleaned prior to returning to supplier for service / repair and must be accompanied by a signed decontamination certificate.